

Doppler Ultrasonic Velocity Sensor

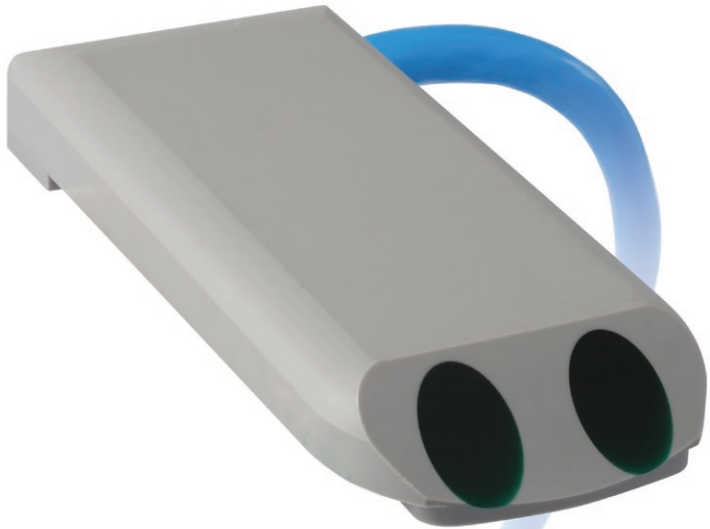

This sensor is used to measure velocity only in full pipes when access to the pipe is available and the pipe can be emptied when installation or maintenance is required.

It can also be used in partially full pipes or open channels in situations where the user is measuring depth by a third party or ultrasonic depth sensor.

- ✓ Doppler ultrasonic velocity sensor with MASP technology
- ✓ Easy to install in existing pipe work with a MACE ZX SnapStrap
- ✓ Operates in regular and irregular cross-sections
- ✓ Reliable under difficult hydraulic conditions

Installation

Use a MACE ZX SnapStrap to install this sensor inside a pipe in minutes. The polycarbonate ZX Snapstrap is tough, secure, does not foul and can be easily removed to take the sensor to another site.

True average velocity measurement with MASP Technology

MACE velocity sensors use continuous wave Doppler ultrasound to measure the speed of dirt, bubbles and other particles in the stream flow.

MACE Doppler ultrasonic velocity sensors utilizing MACE Advanced Signal Processing (MASP) technology "see" across the entire stream profile to give a true average velocity.

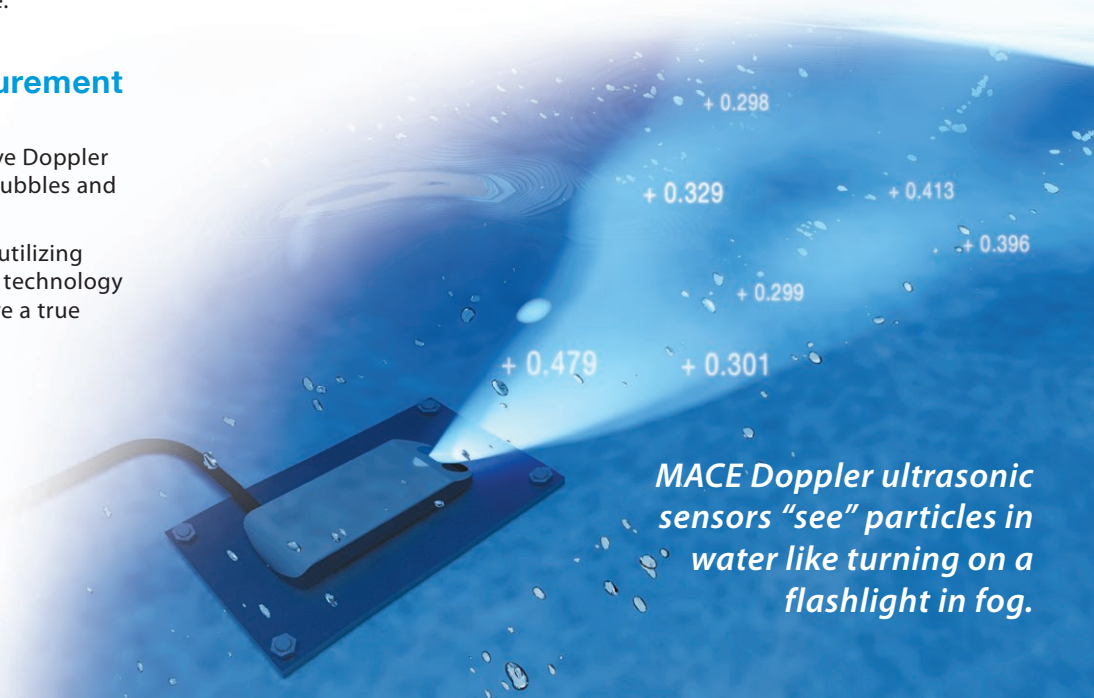

MACE Doppler ultrasonic sensors "see" particles in water like turning on a flashlight in fog.

Doppler Ultrasonic Velocity Sensor Specifications

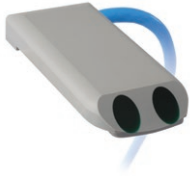

COMPATIBILITY:

The Doppler ultrasonic velocity sensor is compatible with:

- MACE AgriFlo XCi (Requires a Doppler card)
- MACE FloPro XCi (Requires a Doppler card)
- MACE HVFlo XCi (includes factory installed Doppler card)

TECHNICAL SPECIFICATIONS:

ZX SnapStrap mounted, velocity sensor for use in full pipes or open channels (when used in conjunction with a depth sensor)

Pipe size 0.15 to 2.54 m (6 in. to 100 in.) diameter

Max. channel width* 3 m (10 ft.)

Dimensions 125 mm (L) x 50 mm (W) x 17 mm (H)
5 in. (L) x 2 in. (W) x 0.67 in. (H)

Wetted materials PVC and epoxy

Pipe intrusion area 8 cm² (1.24 in²)

* MACE Doppler ultrasonic sensors **will** operate in wider channels, but a reliable stream gauging **must** be performed for best system accuracy.

VELOCITY MEASUREMENT:

Method	Submerged Ultrasonic Doppler
Range	±0.025 to ±8.0 m/s (±0.08 to ±26 ft/s)
Resolution	1 mm at 1.0 m/s (0.04 in. at 3.3 ft/s)
Accuracy	±1% up to 3.0 m/s (±1% up to 10 ft/s)
Urethane sensor cable	9 mm (D) up to 50 m (L) (0.35 in. (D) up to 164 ft. (L))
Min. operating depth	40 mm (1.57 in.)
Max. operating temperature	60° C (140° F)

DIMENSIONAL DRAWING:

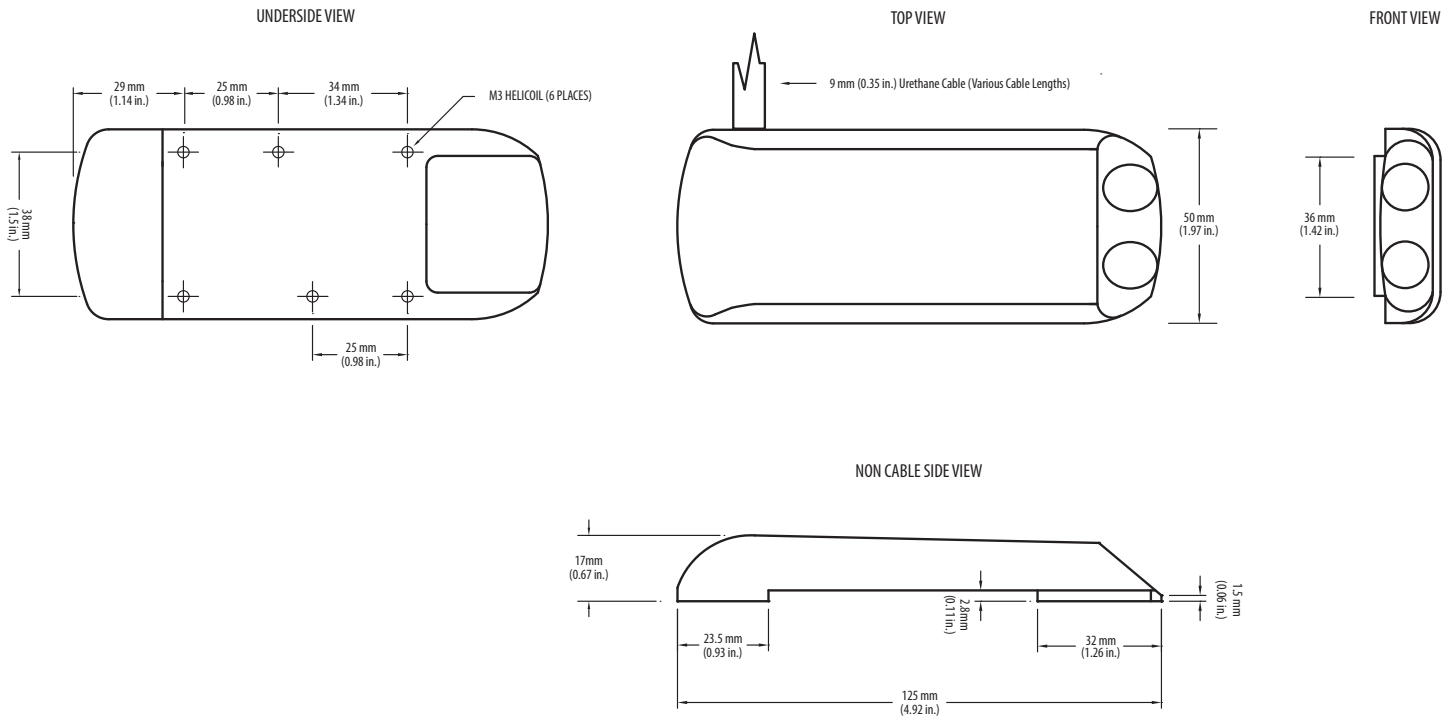

Note to end users: These specifications are subject to change at any time without notice. MACE takes no responsibility for the use of these figures. Please consult MACE for the latest specifications before using them in contract submittals or third party quotes etc. MACE reserves the right to change specifications without prior warning. All quoted figures are based on test conditions and are subject to variation due to site conditions.