

REPLACABLE CERAMIC DEPTH SENSOR

For use in Mace Doppler Area/Velocity Sensors

DOCUMENT
PART No. 825-356 Rev. 1.1

Part No.	Description
850-410	Area/Velocity Sensor 4 m (13.1 ft.) Depth Ceramic Module Replacement includes: sensor and o-ring

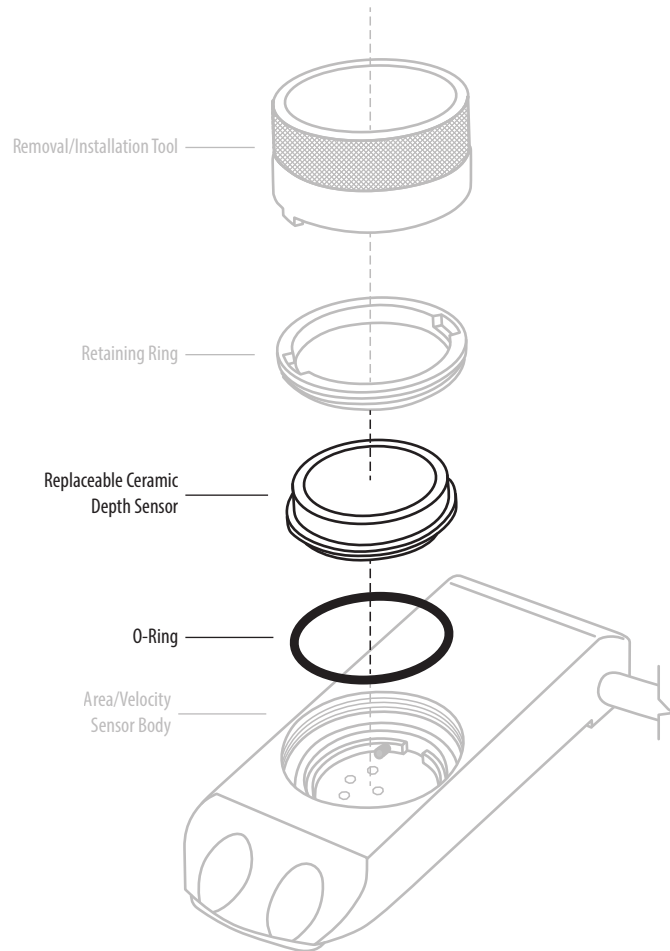

NOTE: Each of these replacement parts can be ordered individually by quoting the applicable Part No. below

Part No.	Description
850-481	Area/Velocity Sensor Replaceable Ceramic Removal/Installation Tool

Part No.	Description
690-366	Replaceable ceramic retaining ring (SS)

Part No.	Description
692-010	O'Ring - BS028

